



Occupational Health & Safety Program

SECTION 3.7.5 FALL PROTECTION PROGRAM

PAGE

(I) INTRODUCTION

**Regulations
Purpose
Policy
Standards**

(II) RESPONSIBILITIES FOR FALL PROTECTION

**Management
Supervisory
Employee
District Safety Personnel**

(III) GENERAL ADVICE

**Factors that May Contribute to Falls
Assessing Hazards
Pre-Job Meetings**

(IV) CATEGORIES OF FALL PROTECTION

- 1. Conventional Fall Protection**
- 2. Fall Restraint**
- 3. Fall Arrest System**
- 4. Control Zones**

(V) COMPONENTS OF FALL PROTECTION SYSTEMS

- 1. Anchors**
- 2. Connecting Devices**
- 3. Body Holding Devices**
- 4. Rescue**

CONTINUED.....

(VI) OTHER FALL PROTECTION SYSTEMS

Fall Arrestor (Rope Grab)
Ladders
Preventing Falls through Roofs/Floors
Preventing Falls from Sloped Faces
Preventing Falls from Scaffolding
Preventing Falls from Bucket Trucks
Preventing Falls through Skylights
Abrasive or Hot Work
Working near Energized Equipment

(VII) OTHER ACCEPTABLE PROCEDURES

APPENDIX 1 - Fall Hazard Assessment Form

APPENDIX 2 - Specific Fall Protection Procedures by Dept. Form

FALL PROTECTION PROGRAM

General Requirements

Fall protection is required when working at heights greater than 3 metres (10 feet).

Fall protection is required when a fall from less than 3 metres (10 feet) involves an unusual risk of injury.

Guardrails or similar means of fall restraint are used whenever possible.

When guardrails (or similar) cannot be used, the employer must ensure that another form of fall restraint is used.

When fall restraint is not possible, the employer must ensure that some form of fall arrest is used.

When a fall arrest system is not possible, a safety monitor system with a control zone can be used in accordance with the regulations.

(I) INTRODUCTION

Regulations

School District No. 54 recognizes that a Fall Protection Program is essential for the safety of all employees working at heights. WSBC regulation Part 11 Fall Protection is the basis for the following work procedures. The regulation mandates that the School District has specific written work procedures that all managers, supervisors and workers are aware of and follow. This is not a matter of individual choice but mandatory for all personnel working in the situations described in this document.

Purpose

This Fall Protection Program provides information, guidelines and forms designed to assist District supervisors and maintenance personnel with the recognition, evaluation, and control of site-specific fall hazards. The Fall Protection Program serves to minimize and/or eliminate the potential for falls from working at heights in various locations.

Policy

School District No. 54 is committed to providing a safe work environment for its employees. In the interest of ensuring a safe and healthy work environment, it is mandatory that all personnel understand and comply with the District's standards. Failure to adhere to this program is a serious violation and poses a undue risk to workers and may result in discipline for any manager, supervisor or worker.

Standards

Where is Fall Protection required?

- Fall Protection (arrest, restraint or other approved system) is required when a fall of 3 metres (10 feet) or more may occur, or where a fall from a lesser height involves an unusual risk of injury, unless otherwise stated in this standard.
- Free fall distance must be limited to 1.2 m (4 ft) without a shock absorber, or 2 m (6.5 ft) with a shock absorber.
- All fall protection equipment shall meet or exceed all applicable CSA standards.
- After a fall has occurred, the complete fall protection system involved must be

tagged and prohibited from further use unless inspected and re-certified as safe for use by the manufacturers, their authorized agents, or by a qualified person.

Where is Fall Protection Not required?

- Fall Protection (arrest, restraint or other approved system) is not required where workers will never be within 2 metres (6 1/2 feet) of an unguarded edge.
- The Fall Protection Zone must be increased if the workers activities increase the risk of falling over the edge (the use of a ladder near the zone is an example of increasing the risk).

(II) RESPONSIBILITIES FOR FALL PROTECTION

Management

Management personnel are responsible and accountable for ensuring that supervisory personnel implement fall protection procedures. This includes but is not limited to the following:

- Managers must ensure that the people in supervisory positions are competent and have the necessary skills, knowledge and authority for implementing the Fall Protection Program.
- Managers must ensure the Supervisors:
 1. Instruct employees in the safe performance of their work;
 2. Adequately supervise employees working at elevations (the exact amount of on-site supervision needed for any particular task will vary depending on the experience of the employees and the hazards of the work involved but all employees must be observed on a random basis by their supervisors frequently enough to confirm that these work procedures are being followed);
 3. Inspect fall protection devices and equipment frequently enough to determine that all workers are doing their regular inspections.
- Managers must ensure that fall protection equipment, as required by legislation, is readily available to all personnel working at heights.

Supervisory

Supervisory personnel are responsible and accountable for ensuring that employees are not exposed to hazards and that required care is taken where a risk of falling has been identified. This includes but is not limited to the following:

- Identifying potential fall hazards in the work areas under their supervision.
- Communicating the identified hazards to employees, ensuring that everyone understands the preventive measures that must be taken and providing an opportunity for workers to express any concerns.
- Ensuring that employees required to use fall protection equipment are trained and are competent in selecting, using and maintaining that equipment.
- Ensuring that employees are fully aware of and have received:
 1. An opportunity to review the Fall Protection Program and/or work plan where required;
 2. Orientation to site specific safety and fall hazards;
 3. Adequate technical instruction and practical training to be competent in meeting the requirements of this program
- Inspecting sites and jobs where employees are working at heights and supervising employees and providing immediate feedback where necessary.

Employee

Employees are responsible and accountable for ensuring that they and their co-workers are not exposed to hazards and that required care is taken where a risk of falling has been identified. This requires:

- Inspecting fall restraint, arrest and rescue equipment to ensure that it is in good working order prior to each use.
- Working in full compliance with safety policies, regulations and this Fall Protection Program.
- Ensuring that no job is undertaken until it can be performed in a safe, efficient and practical manner as outlined in this program.
- Reporting all accidents and close calls to a supervisor as soon as possible.
- Reporting all unsafe conditions and practices and, if possible, correcting them immediately.
- Being familiar with the use and maintenance of fall protection equipment provided.

District Safety Personnel (Health & Safety Officer, OH & S Committee, etc.)

- Assist in hazard recognition, evaluation and control as requested by supervisors or field personnel.
- Assist supervisors in developing written work procedures for site-specific tasks involving work at heights.
- Coordinate Fall Protection Training as requested by managerial and supervisory personnel.
- Liaise with the WCB on behalf of the District to ensure that work practices are in compliance with current regulations.
- Audit the effectiveness of the Fall Protection program through random site visits and discussions with supervisors and workers.
- Ensure that records of pre-job meetings are held and fall hazard assessments are being done regularly.

Remember

Fall protection systems are required where workers can fall at least 3 metres (10 feet) or where a fall from a lesser height may result in serious injury.

Identify potential hazards

Inform all workers about the hazards.

Plan fall protection with the goal to eliminate or reduce the fall hazards.

Plan emergency procedures, including retrieval.

Determine what is the safe way to do the job, not required to be at a height.

(III) GENERAL ADVICE

Factors that May Contribute to Falls:

- Incorrect use of fall restraint, control devices and fall arrest systems
- Unprotected open edges
- Slippery surfaces (i.e., wet, polished, oily – in the case of new steel work)
- Footwear unsuitable for job or conditions
- Obstructions in the work area (equipment, tools, waste materials)
- Incorrect use of ladders
- Inadequate supervision or instruction
- Snags from loose clothing
- Inadequate lighting
- Weather conditions (heavy rain, wind, ice or snow)
- Being struck by moving or falling objects
- Chemical exposure
- Electrical shock
- Markings, openings, or holes not identified or protected
- Moving from one surface to another (level changes)
- Surface not capable of supporting load
- Loss of hand grip
- Moving surfaces
- Sudden acceleration or deceleration

Assessing Hazards

Once potential fall hazards have been identified they must be assessed and a work plan devised.

The Fall Hazard Assessment Form should be used to assess fall hazards. See **APPENDIX 1**.

Pre-Job Meetings

Where any unfamiliar (non-routine) work has potential for falls from height, a pre-job meeting must be held to identify all of the potential hazards. For jobs that involve more than one group of workers or trades, the work must be coordinated – all workers must be informed about the job tasks that are taking place. In this case a pre-job meeting would include a representative from each group.

PRE-JOB MEETINGS ARE THE RESPONSIBILITY OF THE SUPERVISOR

(IV) CATEGORIES OF FALL PROTECTION

The District requires workers to use a fall protection system where they could fall 3 metres (10 feet)), or where a fall from lesser height may result in serious injury. If there are no Specific Fall Protection Procedures for a department (see P. 27), Supervisors and workers should use the following highlighted guidelines from the WCB to assess the level of risk involved in a particular task and select a fall protection system:

WCB Regulation Guidelines: G11.2-2 Selecting a Method of Fall Protection ***Effective August 16, 2000***

Section 11.2 of the OHS Regulation prescribes *a hierarchy of choices* in subsections (2) to (5). The employer must use "guardrails...or other similar means of fall restraint" under subsection (2) if it is practicable for the work process. If it is not practicable, the employer can use another fall restraint system under subsection (3). However, the employer cannot use a fall arrest system under subsection (4) unless it is impracticable to use any fall restraint system under subsections (2) and (3). The control zone system, safety monitor with control zone system and other procedures authorized by subsection (5) can only be used if it is impracticable to use a fall restraint or arrest system required under the preceding subsections.

- *The selection of a method for fall protection depends on what is practicable and is not a matter of free choice for the employer.* What is practicable will depend on the circumstances of each workplace and be a matter of assessment and judgment. The following examples cover some typical situations:
- *Guardrails will generally be considered practicable in high traffic areas at the elevated edges of slabs and floors on buildings or structures under construction.* The temporary removal of guardrails to facilitate work is covered in section 11.5 of the Regulation.

- When a worker needs to be on or near the top plate of a wood frame structure to facilitate part of the erection process, such as to position and fasten joists or trusses to the plate, fall protection is required if the fall distance will be 3 metres or more. Generally this condition will exist along the outer side of the perimeter walls. It will normally be practicable to erect guardrails along the outer side of the wall, or to work from a single pole scaffold (with guardrails if necessary) from either side of the wall, or use another method of fall restraint or arrest.
- If guardrails currently exist, an employer cannot tear them down and substitute another form of fall protection, such as a safety monitor and control zone system, simply because it will make the work easier. The fact that guardrails currently exist suggests that it is practicable to use that form of fall protection.
- Where a roof is under repair, it may not be practicable to install guardrails due to such factors as the small number of workers involved and the short duration of the job. In this situation, it will generally be practicable to use a fall restraint system consisting of a belt or harness and a lifeline, connected to a suitable anchor, and rigged to prevent the worker from going beyond the unguarded edge(s).
- A fall arrest system will likely be appropriate where there is no sizable work platform, for example, on a bridge girder, or where it is not reasonable to expect use of any fall restraint system due to the small number of workers and the short duration of the job.

Four categories of fall protection are outlined below in their preferred order of selection. The following options can be used if the fall hazard cannot be eliminated from the job.

1st Option: Conventional Fall Protection

Preventing workers from reaching the edge of a potential fall situation by passive or traditional methods. Examples include:

- Guardrails
- Handrails
- Barriers
- Ladder cage loops



2nd Option:

Fall Restraint

Where it is not practical to install guardrails or barriers, employees working in excess of 3 metres (10 feet) above grade (or less when working over other hazards) shall be protected from falling by use of a Fall Protection system. Fall restraint systems prevent workers from approaching the falling hazard. The system is intended to limit a worker's movement so the worker is unable to reach a location where there is a risk of falling. This includes work-positioning systems that use full body harnesses to attach the worker to an anchor leaving both hands free to work. Under no circumstances should a travel restraint be rigged so that a worker is in a position to fall.

Remember

Fall Arrest Systems should only be considered if conventional fall protection and fall restraint systems are not practical.

3rd Option: Fall Arrest System

Fall arrest systems protect workers after they fall by stopping them before they hit the surface below.

This includes safety nets or a full body harness connected to lanyards or lifelines to secure anchors.



4th Option: Control Zones

Where it is not practical to protect employees in excess of 3 metres (10 feet) above grade with guardrails, barriers, a Fall Restraint System or a Fall Arrest System, a Control Zone System will be provided. Control Zones are designated areas in which workers enter a potential fall hazard such as the unguarded outer perimeter of a flat roof, excavation, etc. These areas require a trained safety monitor to supervise workers close to any potential falling situations. The monitor is responsible for surveying the work for potential falling situations and warning workers about these situations.



The Control Zone must be at least 2 meters (6-1/2 feet) wide from the edge of the structure, hole, etc. The Control Zone must be physically marked. The height of the flagging must be maintained at no more than 45” and no less than 40”.

(V) COMPONENTS OF A FALL PROTECTION SYSTEMS

4 components must be presented in every fall restraint and/or fall arrest system:

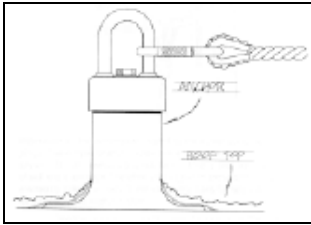

Roof Top Anchor



Lanyard



Full Body Harness

- 1. Anchors
- 2. Connecting Devices
- 3. Body Holding Devices
- 4. Rescue or Self-Retrieval

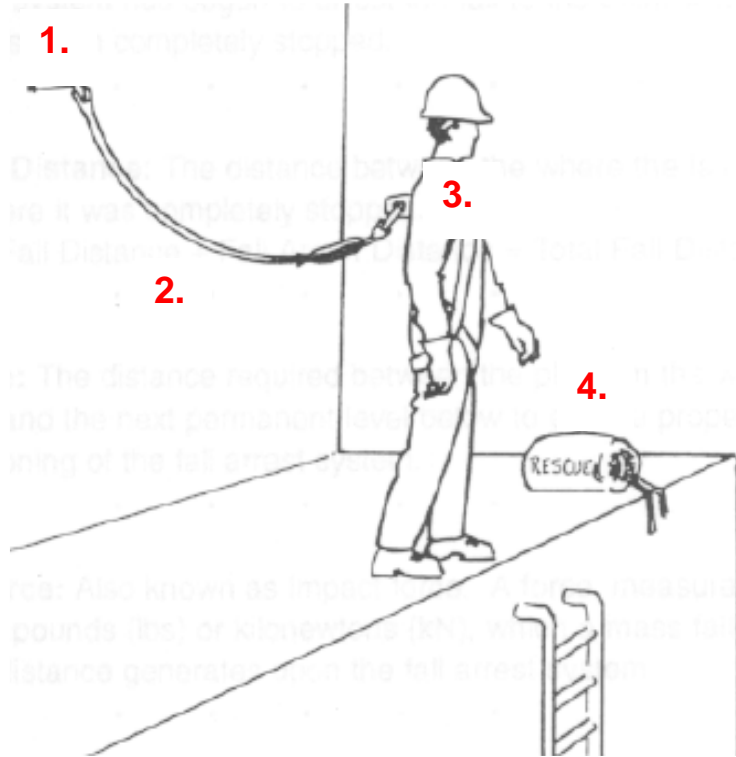

1. Anchors

Definition:



An anchor is a secure means of attachment to which the fall protection System is connected. It is the point of contact between a fall protection System and an unquestionably strong attachment point.

Strength Requirements:

The force exerted on an anchor depends on three factors:

1. free fall distance
2. mass
3. type of anchor

**Fall Restraint: 800 lbs
(temporary anchors)**

**Fall Arrest: 5000 lbs
(engineered anchors)**

Types of Anchors:

Engineered

- Designed and stamped by a professional engineer.
- Have drawings associated with them and should never be altered without approval from a professional engineer

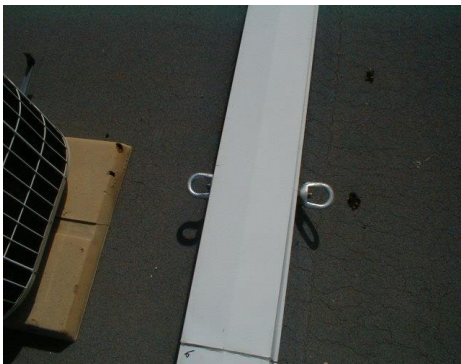

- Frequently used at established work areas and are specifically designed to withstand the forces generated by a person falling.

Temporary

- Created with existing structures at the job site for transient tasks.
- Usually created with web, rope or cable slings.
- Used for fall restraint only.

Temporary Anchors

Selection and installation of temporary anchors requires training and knowledge.

The anchorage is very important in the entire fall protection system selected. Never guess. If there are any questions contact your supervisor.

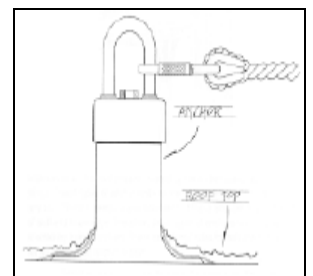

The following points should be considered when selecting an anchor point.

- Anchorage should be directly above the work area to minimize the swing-fall hazard or pendulum effect.

- The anchorage must be extremely strong. Rule of thumb: the anchor should be able to hold the weight of a pick-up truck.
- An engineered anchor point must be stamped and certified by an engineer.
- All nearby hazards must be considered (chemicals, machinery, etc)
- Watch for sharp edges
- Know which equipment to use and its proper use
- Consider access to work area
- Consider total potential falling distance and swing fall hazards
- Shock absorption is necessary for fall arrest systems

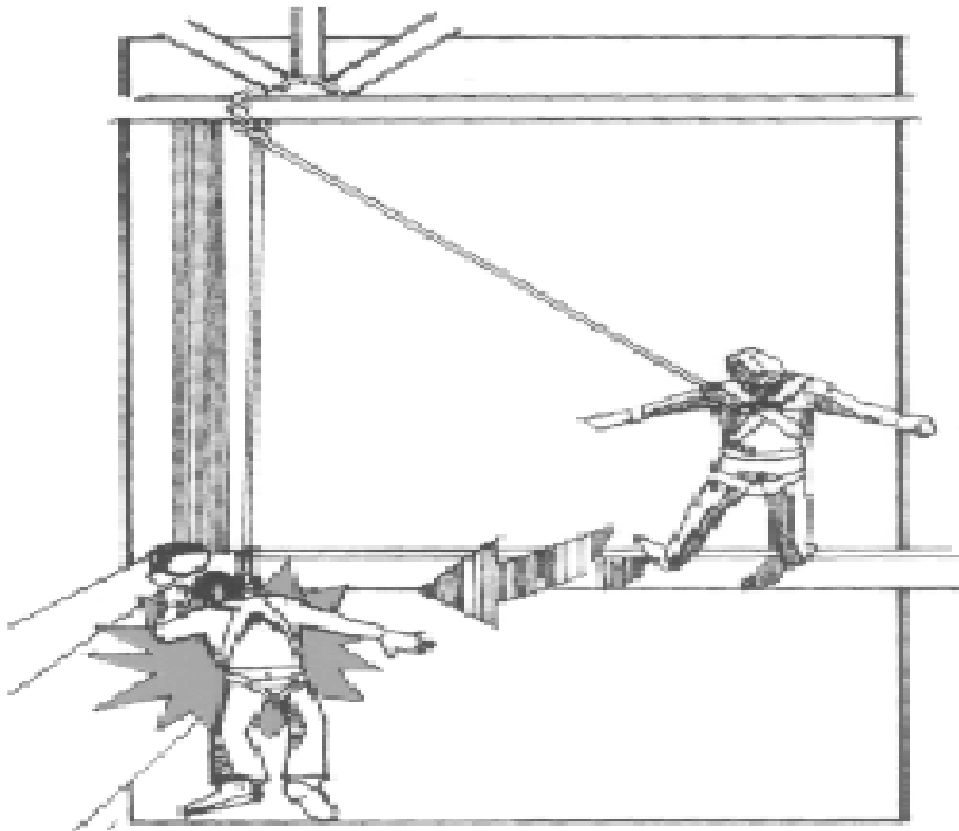

SWING FALL HAZARD

2. Connecting Devices

Definition: A device that connects the worker's body holding device to an anchorage.

There are many different types of connecting devices, each with its own purpose.

Examples of connecting devices include:

- Snap hooks
- Carabiners
- Lanyards & Shock Absorbers

Snap Hooks

Snap hooks are usually found at the end of a lanyard, they provide a way to secure the lanyard to an anchor and the body holding device (harness).

When Selecting Snap Hooks, Look for:

- Self-locking
- Stamped strength rating (minimum 5,000 lbs.)
- Drop forged steel
- User friendly – can it be used while wearing gloves?
- Is the locking mechanism easy to use?

Snap Hooks Are To Be:

- Used by properly trained employees only
- Used with compatible double locking connectors
- Replaced if subject to impact loading (after a fall)
- Not exposed to chemicals (may damage the finish)

Before Each Use Check That:

- The locking mechanism functions properly
- The body of the hook is not twisted
- Remove from service and discard if it does not pass inspection



NEVER:

- Attach more than one snap hook to the D-ring on a harness
- Snap two hooks together
- Alter the device in any way
- Work without independent fall arrest system if there is a danger of a fall
- Rely on the feel or sound of the hook engaging, check that each hook is properly closed and locked

Carabiners

Carabiners are gated links that connect components of a personal fall protection system.

When Selecting Carabiners Look For:

- Locking mechanism, preferably self-locking
- Ultimate load capacity of 5000 lbs
- Load capacity clearly marked
- User friendly – can it be used with gloves etc.

Carabiners Are To Be:

- Used only by properly trained employees
- Used with compatible locking connectors
- Inspected if subject to impact loading (after a fall or if it is dropped)
- Not exposed to chemicals which may damage the finish

Cross Gate Loading

Carabiners are meant to be loaded along their spine; their strength is decreased when loads are placed on the gates.

Lanyards

A flexible line of webbing of synthetic or wire rope that is used to secure a body holding device to a lifeline or anchor.

When Selecting Lanyards Look For:

- CSA approved
- Shortest lanyard possible to minimize free fall distance without limiting job performance
- Wire rope when a tool is used that could sever, abrade or burn a lanyard or safety strap
- Capacity to support at least 5,400 lbs.
- Self-locking snap hooks at each end

Lanyards Are To Be:

- Used only by properly trained employees
- Used with compatible locking connectors
- Replaced if subject to impact loading
- Not exposed to chemicals which may damage the lanyard
- Protected from sharp edges and abrasion
- Used to limit free fall distance to 4 feet if shock absorbers are not used used to limit free fall distance to 6.5 feet if shock absorbers are used

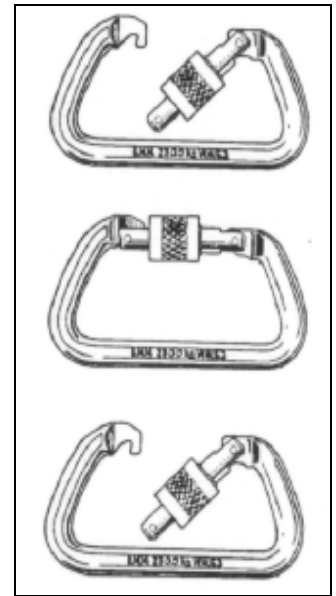

Cross-loading a carabiner along its minor axis (gate to spine) should always be avoided, as carabiner strength in this direction is usually less than half its major axis strength.

Before Each Use Check That:

- Lanyard is free of burns, cuts, fraying and knots.
- Snap hooks lock properly and are not distorted.
- Remove from service and send for overhaul or discard if it does not pass inspection.

Shock Absorbers

Shock absorbers are often built into lanyards. The purpose is to reduce the loading that occurs during a fall.

When Selecting Shock Absorbers They Must Be:

- CSA certified

Shock Absorbers Are To Be:

- Used by properly trained employees only
- Used with compatible locking connectors
- Replaced if subject to impact loading
- Not exposed to chemical which may damage the fabric
- Protected from sharp edges and abrasion

Before Each Use:

- Ensure that shock absorber is free of any tears, abrasions, etc.
- Ensure that shock absorber has not deployed
- Allow for the potential increase in the total fall distance with shock absorber deployed. Shock absorber extension distance must be added to free fall distance for a maximum total fall of 6.5 feet or manufacturer's instruction (which is ever less)

NEVER:

- **Attach more than one hook onto a D-ring**
- **Alter the device in any way**
- **Work without independent fall arrest if there is a danger of a fall**



Retractable Lanyards

Retractable lanyards are usually made of synthetic webbing wound on a drum. The unit has a spring mechanism that allows for full retraction of the lanyard within the housing when the lanyard is not in use. When the force of a fall is exerted upon the retractable lanyard, it locks up much like a seat belt and limits free fall to within usually 2 feet.

Remember

Inertia reels may be less effective for certain applications, (eg. Stopping a person falling down an inclined surface). Inertia reels should be only sited from vertical to 45 degrees.

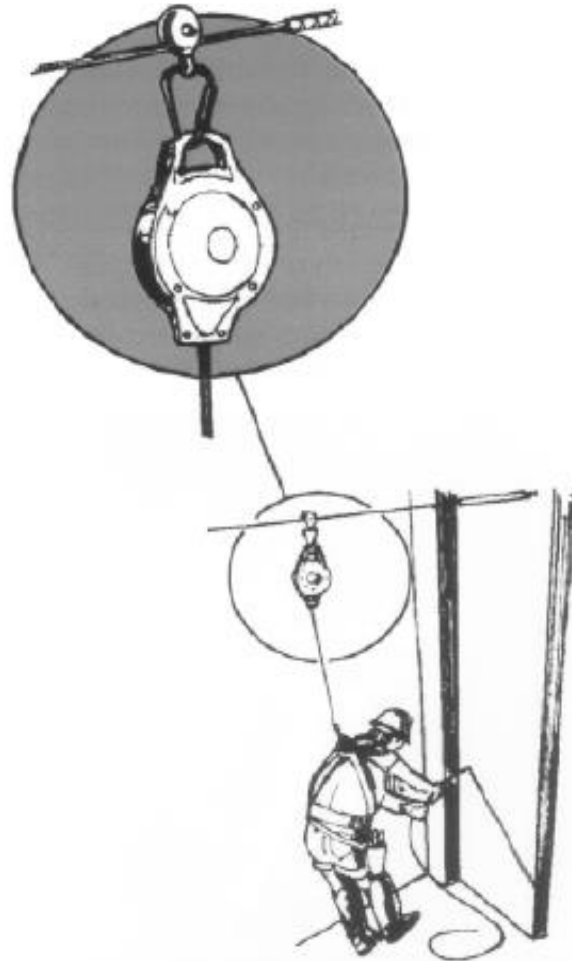

NEVER:

- **Use a retractable lanyard as a working support by locking the system and allowing it to support the user during normal work.**

3. Body Holding Devices

(a) **Waist Belts**

Although WCB permits waist belts for travel and fall restraint, they are not permitted for any use by District employees. The District's standard is to use a full body harness for all fall protection systems.

Waist belts are not to be used as part of any fall protection system



(b) **Fall Arrest/Restraint Harnesses**

Fall arrest/restraint harnesses must be of the full-body type.



Types of Full Body Harnesses

Harnesses are rated differently depending on the application. They differ in their connection points. Harnesses will have a letter stamped on the webbing indicating what type of harness it is. An “A” type harness will have “A” stamped on webbing. Type A is the only type allowed to be used by School District 54 employees.

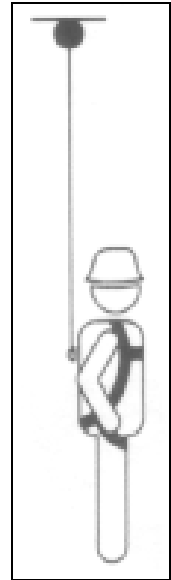

“A” Type Arrest

- The most basic
- Has one D-ring attached to the harness between the shoulders at the back
- Harness should have a sub-pelvic strap and a sliding D-ring

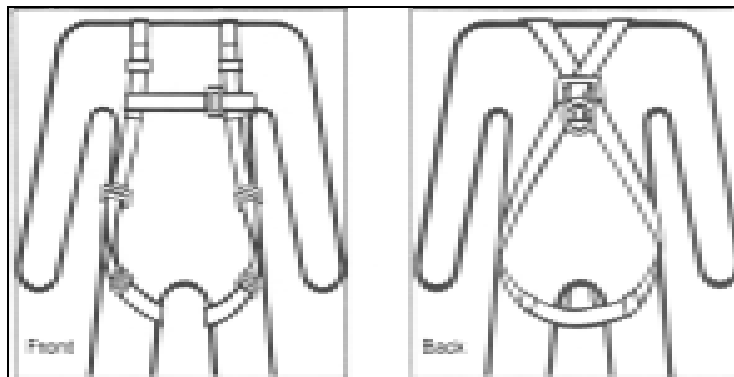

THIS TYPE OF HARNESS IS NOT PERMITTED.

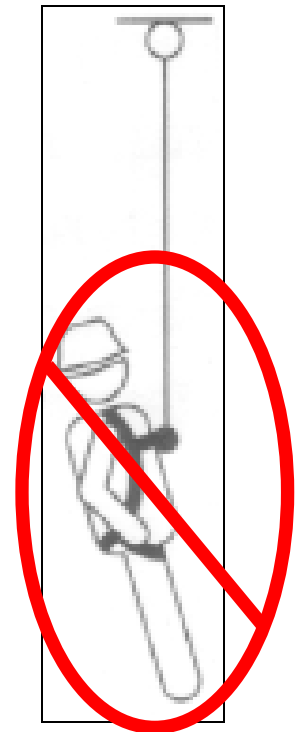

Hook-up Procedures

There are some important points to note about the proper hook-up for fall arrest and/or fall restraints:

- Always check all equipment for wear and tear.
- Check that your set-up is all working after taking breaks to do other tasks and at lunch and coffee – **never** assume that everything will always be the way you left it. Another worker may have used your equipment or moved it and not connected it back up properly.
- Check that locking mechanisms are right side up. Arrow will indicate proper way to assemble:



- Plan your work so that you will not be working with too much slack in your line



TOO MUCH SLACK IN LINES



WORKER HAS ADJUSTED LINES PROPERLY

4. Rescue

The fourth and final component of a fall protection system is the rescue or self-retrieval component.

Fall protection systems are designed to minimize workers' exposure to fall hazards and to reduce their risk of injury if they do fall. Just installing a fall protection system does not come with a 100 percent worker protection guarantee. There are many steps, procedures and inspections required to ensure this system works effectively and the rescue component must be a part of this system.

The District has established the following guidelines to ensure that workers who do fall or are injured as the result of a fall receive immediate attention. Emergency response procedures should be fully documented through the fall protection planning process before workers install or use any arrest/restraint system.

The following checklist/guidelines can be used to develop emergency response planning procedures, responding to emergencies, and investigating accidents. Emergency procedures are required as part of a fall protection plan.

Emergency Response — Planning Guidelines

1. Before Onsite Work Begins:

- Hold a pre-job meeting. Supervisors to review job with employees and assess fall hazards.
- Conduct one or more training sessions between key on-site personnel and emergency responders (first aid personnel at school sites).
- Re-evaluate and update the emergency response plan if on-site work tasks change.

2. As On-Site Work Progresses:

- Identify on-site equipment that can be used for rescue and retrieval. Examples: boom lifts, man lifts, ladders, and forklifts.
- Maintain a current equipment inventory at the site. Equipment may change frequently as the job progresses.

3. Emergency Response Actions:

- Call 250 847 8808 in Smithers and Telkwa and 250 845 2900 in Houston or other emergency numbers indicated on the emergency response plan. First responders should clear a path to the victim. Others should be sent to direct emergency personnel to the scene.

- Make sure only qualified personnel attempt a technical rescue (Smithers Fire Department)
- Prohibit all non-essential personnel from the fall-rescue site.
- Talk to the fall victim; determine the victim's condition, if possible.
- If the victim is accessible: The First Aid Attendant is to check the vital signs and make the worker comfortable. If necessary, administer CPR and attempt to stop bleeding.
- Do not attempt a solo rescue if victim is suspended. Wait for trained emergency responders.

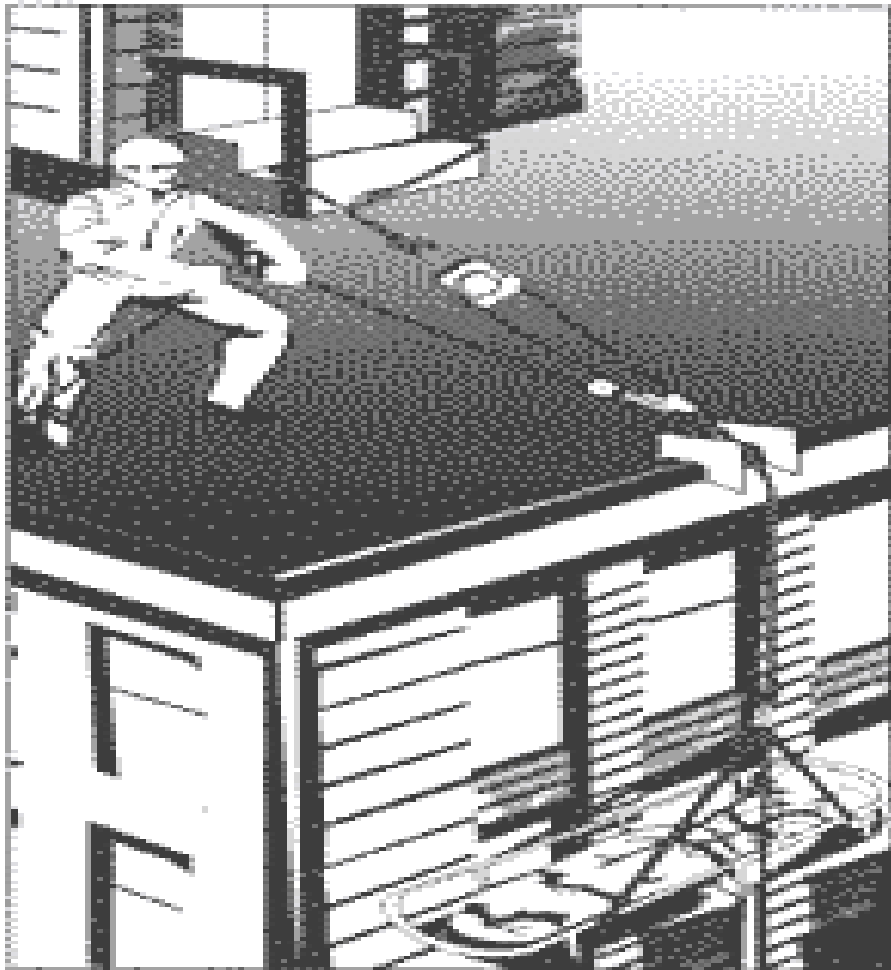

(IV) OTHER FALL PROTECTION SYSTEMS

Stationary System

Protects the worker from falling but limits the ability for the worker to move freely.

Traveling System

Protects workers but moves with the worker as (s)he moves in a vertical or horizontal plane.



It is extremely important to use rope grabs only with compatible ropes



Horizontal Traveling System

Allows the worker to travel in a horizontal plane.

The system may include:

- retractable lifelines
- fall arrestor (rope grab)
- vertical lifeline attached to it
- in addition to the other four components needed in a fall protection system.

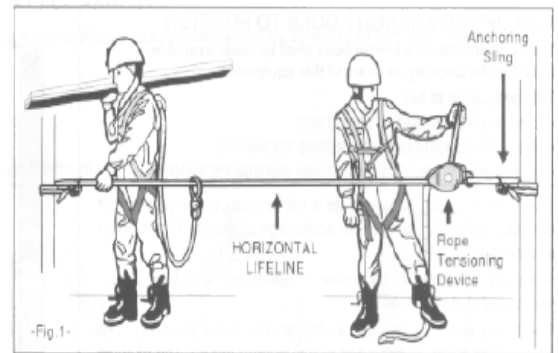

Retractable Lifeline

- Also known as a fall arrest block or a safety block
- As the worker moves up and down a structure, the lifeline, which is coiled in the housing, extends and automatically retracts under tension
- The internal design of the fall arrestor consists of a centrifugal locking mechanism

When Using A Retractable Lifeline:

- Check the operating condition of the centrifugal locking mechanism.
- Use only as recommended by the manufacturer.
- Never climb above the retractable lifeline's anchor point.
- Assess the risk of swing fall hazards – horizontal hook-up creates this risk.
- Always refer to manufacturer's recommendations.
- Do not let the cable run over an edge.
- Do not use the device on its side.

Fall Arrestor (Rope Grab)

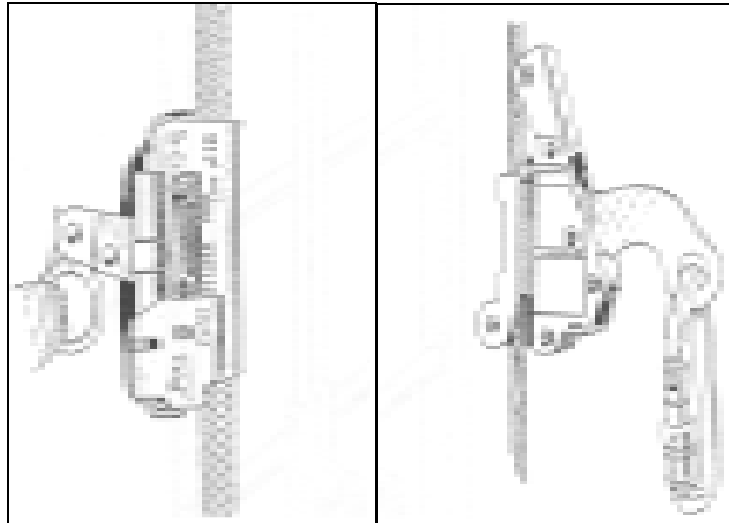

- Fall arrestors are cam-activated devices that slide vertically along a rope or cable as the worker moves.
- The fall arrestor is usually attached to the dorsal D-ring through a shock absorbing lanyard.

When Using A Fall Arrestor (Rope Grab):

- The vertical lifeline should be weighted to prevent the arrestor from dragging it up during climbing which would create a slack line hazard.
- The rope grab must be installed on the rope with the arrows pointing upward.
- The label on the rope grab indicates which ropes are compatible.
- Ensure that the rope grab will not slide off the end of the lifeline.
- Tying the lifeline to a structure will help to minimize horizontal movement, which may create a swing fall hazard.

Ladders

Preventing Falls From Ladders

4 to 1 Rule



Proper 4 to 1 set-up outside a portable



Instability - Base of ladder positioned too far from wall. Sudden slipping can occur.

- Ensure ladder is resting against a firm structure and has 4 secure points of contact
- Set up ladders with a 4 vertical to 1 horizontal slope
- Extend ladders (other than a stepladder) approximately 1 m (3 feet) above a safe landing or parapet wall
- Tie, block, or otherwise secure the ladder to prevent it from slipping.
- Protect ladders used in locations such as doorways or passageways from being bumped or knocked over
- If required due to location or length, secure the ladder at the bottom and mid-point
- Only short duration work can be performed from a position on the ladder without utilizing fall protection systems. Note: 3 point contact must be maintained at all times
- Use a fall protection system where a fall of 3 meters (10 feet) or more may occur or a fall from less than 3 meters involves an unusual risk of injury
- Only one worker at a time is allowed on a single width ladder
- Do not carry heavy objects while climbing up or down a ladder – use lifting equipment, ropes & pulleys, etc.
- Do not use ladders for support, scaffold planking or any horizontal load-bearing support, except ladder jack applications
- Do not use ladder-type material hoists for roof access unless it is designed for that purpose

Climbing and performing short duration work from ladders

- Always face the ladder
- Never work or reach outside the railings of the ladder
- Always keep 3 point contact with the ladder (two legs and one arm)
- Do not carry objects while climbing up or down the ladder

Ladder Tie-Offs

- Tie-off with at least 3 rungs above roof line
- Tie back base of ladder to structure if on unstable ground
- Use proper eye-bolts whenever possible
- Use rope to tie off left and right. Do not use bungee cords (tripping hazard)



Ladder tied-off with rungs well above roof



Best Practice Note: tie-offs with separate nylon ropes to eyebolts left & right

***For more specific instructions on ladders refer to Facility Services Safe Operating Procedure No. 0005
Sept. 5, 2001***

Preventing Falls Through Roofs/Floors

Remember

Coverings must be capable of supporting all loads they may be subjected to

If plywood is used to cover openings the minimum thickness should be 19 mm (3/4") with proper supports

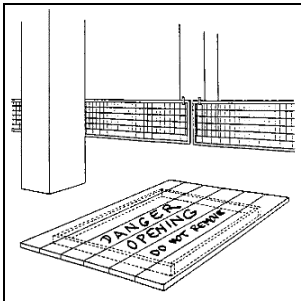

Unprotected holes are a severe hazard and must be covered

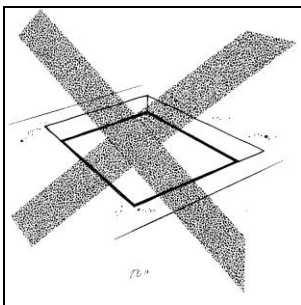

When it is necessary to temporarily remove guardrails or covers to complete work, upon completion of work they must be immediately replaced

- Substantial covers must be securely installed to prevent falls through roof and floor openings
- Such covers shall be clearly marked indicating that there is an opening below
- Warning signs and covers shall be checked periodically and be well maintained
- When a roof or floor opening must remain open, a guardrail or other method of preventing access must be provided
- Guardrails must be made of solid construction in accordance with WCB Regulations

When work must be performed near unprotected openings from which a fall of 10 feet or more could occur, access must be restricted to workers wearing full body harness and lifelines secured to proper anchorage.

Whenever work is being done on a roof where a fall from 3 metres (10 feet) or more may occur or where a fall from a lesser height may involve an unusual risk of injury, fall protection systems and devices must be used to prevent such falls. The type of system used depends on the slope of the roof. A roof's slope is the number of inches it rises for every 12 inches of horizontal run. A roof with a "4-in-12 slope" rises 4 inches for every 12 inches of horizontal run.

Sloped roofs less than 4 in 12 (~33 degrees)

A control zone with monitor system is permitted on roofs less than 1 in 3 where other fall protection systems are impractical.

Sloped roofs more than 4 in 12 (~33 degrees and less than 8 in 12 ~67 degrees)

Employees working on roofs over 4 in 12 are required to wear a CSA approved safety belt, for fall restraint only, or a full body safety harness attached to a securely anchored life line for fall arrest protection.

Sloped roofs more than 8 in 12 (~67 degrees)

Employees working on roofs over 8 in 12 must use a personal fall protection system or personnel safety nets, and horizontal roof strapping or 2 x 6 toe boards must be installed if the roofing material permits it.

Remember

Safety nets, monitored control zones, or other fall protection devices must be used where a fall from 3 metres (10 feet) or more may occur or where a fall from a lesser height may cause a serious risk.

Other Considerations

- Roof jacks may be utilized to provide a solid footing for employees working on sloped roofs based on the activities performed and taking into consideration any other additional hazards.
- Crawl boards or ladders may also be used. Ladders must be securely fastened over the roof ridge (not eaves troughs) for support.
- All fall control devices must be inspected prior to use, made of substantial construction, well maintained and provide effective slip and fall prevention for the conditions.

Preventing Falls from Sloped Facings

Whenever work on a sloped face (embankment) may result in a fall, one or more of the following fall protection measures will be used:

- Where practical, ladder jack scaffolds may be used provided that the ladders can be secured down against tipping and that planking will be securely fastened down.
- A controlled descent device with attachment to a securely anchored lifeline may be used to rappel into position if:
 - It is of the stopping, or ‘dead man’ style, or
 - An automatic stopping device such as a mechanical rope grab or Prusik sling is incorporated into the protection system
 - The lifeline is kept under tension at all times to protect the worker from free falling

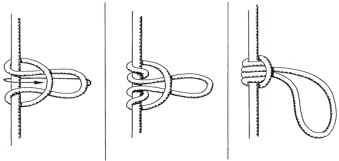

Tying a Two-Wrap Prusik Knot

Preventing Falls from Scaffolding

- Use the ladder or stairs provided to gain access to a platform where a fall of 3 metres (10 feet) or more may occur, or where a fall from lesser height involves an unusual risk of injury
- Prior to commencement of the work, the scaffold must be inspected by a competent and qualified individual
- Ensure guardrails are in place if platform exceeds 10 feet in height
- If guardrails need to be temporarily removed for unloading/loading of equipment and supplies, employees working around the unguarded edge must use another type of fall protection system

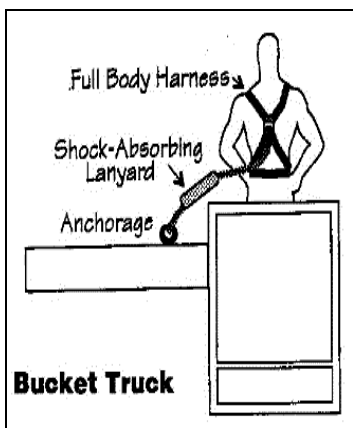

Preventing Falls From Bucket Trucks

When employees are working in a bucket engineered with an anchor point, they must wear a full body harness attached to the load hook by a shock-absorbing lanyard. Workers shall never climb railings or sides of bucket/platform to increase their reach. Re-manoeuvre the bucket/platform or use better-suited lifting equipment. Always follow manufacturer's instructions.

Preventing Falls Through Skylights

- Ensure railings or screens are guarding all skylights prior to any work performed
- Consider whether safety netting can be installed
- Place decals on each skylight warning individuals not to sit or step on the them

For More Info

Refer to WCB OH&S Regulations
Part 13.

Remember

What works well at one job
site may not work at the next
site.

Abrasive or Hot Work

When tools/equipment are used or work processes are performed that could severely abrade or burn conventional lanyards, safety straps or lifelines, wire rope or double lifelines must be used.

Working Near Energized Equipment

If performing work where conductive lanyards, connecting devices, and safety straps cannot be used safely, two non-conductive lanyards or safety straps can be used or another means of fall protection providing equivalent or more protection.

Preventing Electrical Shock

- Be aware of overhead electrical power lines
- Avoid contact
- Use an alternate means or location to access work areas
- If unsure of clearance requirements, consult with your supervisor

(VII) OTHER ACCEPTABLE PROCEDURES

Note: Use of these types of procedures requires a "fall protection plan".

WCB Regulation Guideline: G11.2-4 Work procedures acceptable to the board

Effective August 16, 2000

Section 11.2(5)(c) of the OHS Regulation allows the use of "other procedures acceptable to the board" where the fall restraint and fall arrest methods authorized by sections 11.2(2) to (4) are not practicable or will result in greater hazards.

Some typical situations where work procedures *may be acceptable* because other forms of fall protection are impracticable are:

1. *Installation or removal of fall protection equipment* (first person up/last person down)
2. *Light duty work for short duration*, for example:
 - *Working off of a portable ladder doing a "light duty task", such as inspection or painting, where the duration of work at each spot where the ladder is set will be for approximately 15 minutes or less. While doing the task, the worker must keep his/her center of gravity (worker's belly button) between the side rails of the ladder, and must generally have one hand available to hold on to the ladder or other support to maintain three points of contact (see also section 13.8(3)). (Note: If the duration of the work on a ladder is likely to exceed 15 minutes, some form of fall restraint or fall arrest protection should be used.)*
 - *Roof inspection or estimating*, provided the worker minimizes exposure to any unguarded edge as much as possible, and provided other factors such as environmental (wind, ice), roof slope and surface finish do not present an undue hazard.
 - *Brief transfers between fall protection systems* where the worker is protected by having a "3 point stance" (two feet placed firmly on a suitable supporting surface along with one hand supporting the worker, while the other hand is used to transfer a connection from one fall protection system to another.)
3. *Work requiring constant re-positioning*, for example:
 - *During the primary connection of skeletal structures, workers employed in the initial placement of skeletal members requiring climbing and walking on the bare structure may, depending on the particulars of the work to be one, be covered by section 11.2(5)(c). Trades with activities of this nature would include scaffold erectors, tower erectors, blowpipe ventilation erectors, structural steel erectors, and tower crane erectors. Workers on the structure engaged in welding, bolt installation, other fitting*

out work and climbing or walking on skeletal members should be able to use the fall protection methods referred to in sections 11.2(2), (3) and (4).

- Workers on roofs engaged in a process that will foul lifelines, such as roofing tar work, should work under the protection of procedures as specified in sections 11.2(5)(a) and (b).
4. *Emergencies* such as fire fighting (see subsection 31.17(4)), or the correction of an unsafe condition.
 5. Use of the normal fall protection methods results in greater hazard, for example, if using an auxiliary escape apparatus provided to meet the requirements of section 23.39 of the OHS Regulation.

If work procedures are used under section 11.2(5)(c), *section 11.3 requires there be a fall protection plan for the work site.*